

### MAL Series Aluminum alloy Mini Cylinder

Overall Dimensions

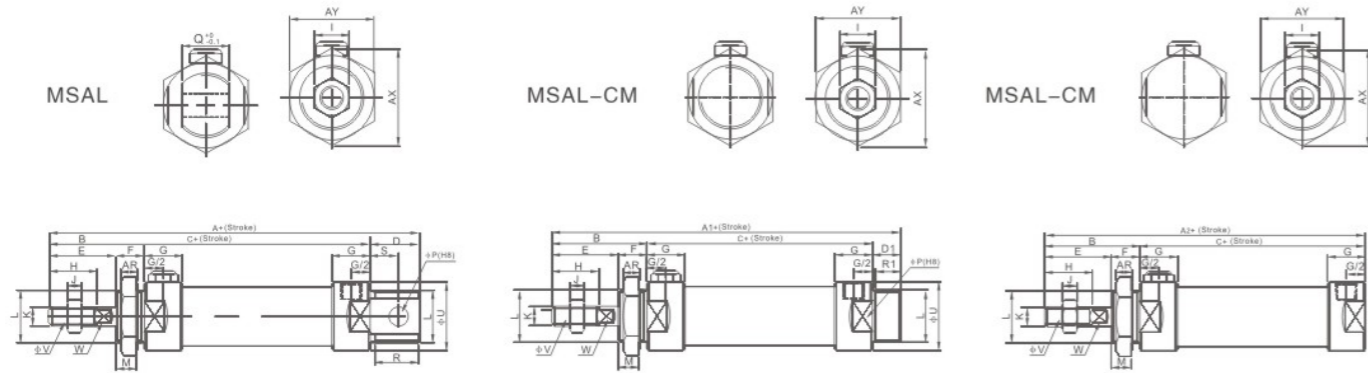

Dimension Sheet

Symbol	A		A1		A2		B	C		D	D1	E	F	G	H	I	J
	Bore/Stroke	0-50	51-100	0-50	51-100	0-50		51-100	0-50								
20	131	156	122	147	110	135	40	70	95	21	12	28	12	16	20	12	6
25	135	160	160	153	114	139	44	70	95	21	14	30	14	16	22	17	6
32	141	166	166	153	114	139	44	70	95	27	14	30	14	16	22	17	6
40	165	190	190	177	138	163	46	92	117	27	14	32	14	22	24	17	7

Inside Diameter/Symbol	K	L	M	P	Q	R	R1	S	U	V	W	X	AR	AX	AY
20	M8×1.25	M22×1.5	10	8	16	19	10	12	29	8	6	G1/8"	7	33	29
25	M10×1.25	M22×1.5	12	8	16	19	12	12	34	10	8	G1/8"	7	33	29
32	M10×1.25	M24×2.0	12	10	16	25	12	15	39.5	12	10	G1/8"	8	37	32
40	M12×1.25	M30×2.0	12	12	20	25	12	15	49.5	16	14	G1/4"	9	47	41

Overall Dimensions

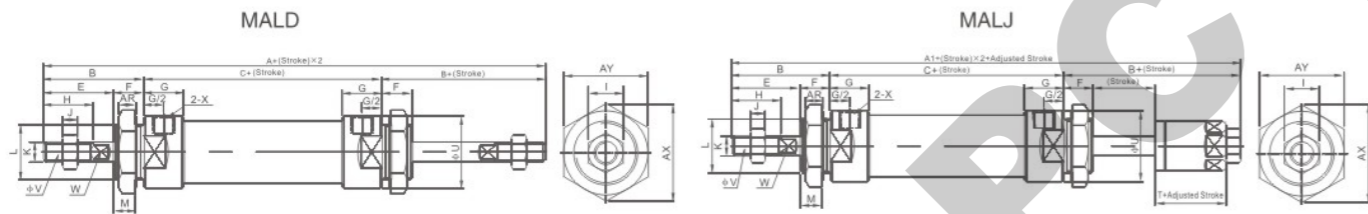

Dimension Sheet

Inside Diameter/Symbol	A	A1	B	C	E	F	G	H	I	I	K
20	150	147	40	70	28	12	16	20	12	6	M8×1.25
25	158	155	44	70	30	14	16	22	17	6	M10×1.25
32	158	155	44	70	30	14	16	22	17	6	M10×1.25
40	184	180	46	92	32	14	22	24	17	7	M12×1.25

Inside Diameter/Symbol	L	M	U	V	W	X	AR	AX	AY	T
20	M22×1.5	10	29	8	6	G1/8"	7	33	29	19
25	M22×1.5	12	34	10	8	G1/8"	7	33	29	21
32	M24×1.5	12	39.5	12	10	G1/8"	8	37	32	21
40	M30×2.0	12	49.5	16	14	G1/4"	9	47	41	21

### CM2 Series Stainless Steel mini Cylinder

Ordering Code

**CM2** × **32** × **150** - **A**

**Series Code**  
 CM2B:Normal Type  
 CDM2B:Attach magnet Type

**Cylinder Bore**  
20mm-40mm

**Stroke**  
0~1000mm

**Buffer**  
Blank:Rubber Buffer  
A:Air Buffer

CDM2B 32 x 50      CDM2B 20 x 50

Internal structure

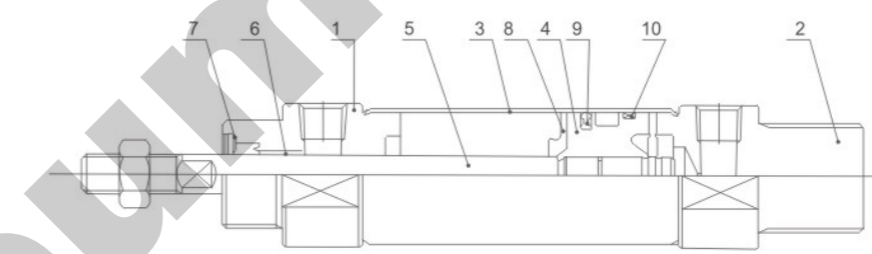

NO.	Designation
1	Front Cover
2	Back Cover
3	Barrel
4	Piston
5	Piston rod
6	Oiled Bearing
7	Front Cover Seal Ring
8	Anti-crash cushion
9	Piston Seal
10	Wear Ring

Specification

Bore(mm)	20	25	32	40
Working Medium	Air			
Motion Pattern	Double action			
Ensured Pressure Resistance	15.3kgf/cm <sup>2</sup> (1.5Mpa)			
Max.pressure	10.2kgf/cm <sup>2</sup> (1.0Mpa)			
Min.pressure	0.5kgf/cm <sup>2</sup> (0.05Mpa)			
Operating Temperature Range	-10~+70℃			
Operating Speed Range	50~750mm/s			
Buffering	Rubber buffer(Standard),Air buffer(Optional)			
Margin of Stroke Error(mm)	+1.4 0mm			
Port size	G1/8"	G1/8"	G1/8"	G1/4"

Overall Dimensions

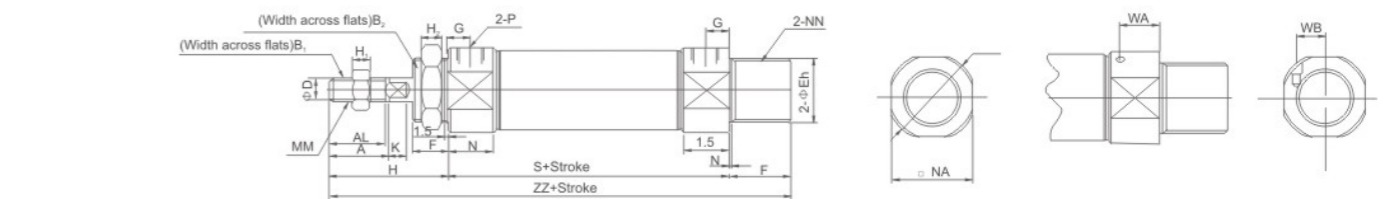

Dimension Sheet

Diameter	Stroke range	A	AL	B1	B2	D	E	F	G	H	H1	H2	I	K	MM	N	NA	NN	P	S	ZZ	WA	WB
20	~300	18	15.5	13	26	8	20 <sup>0</sup> <sub>-0.033</sub>	13	8	41	5	8	28	5	M8×1.25	15	24	M20×1.5	1/8	62	116	11.5	8.5
25	~300	22	19.5	17	32	10	26 <sup>0</sup> <sub>-0.033</sub>	13	8	45	6	8	33.5	5.5	M10×1.25	15	30	M26×1.5	1/8	62	120	11.5	10
32	~300	22	19.5	17	32	12	26 <sup>0</sup> <sub>-0.033</sub>	13	8	45	6	8	37.5	5.5	M10×1.25	15	34.5	M26×1.5	1/8	64	122	11.5	11.5
40	~300	24	21	22	41	14	32 <sup>0</sup> <sub>-0.033</sub>	16	11	50	6	10	46.5	7	M14×1.5	21.5	42.5	M32×2	1/4	88	154	14	15