

Assembly Kits for Pneumatic Cylinder

MA/MA6432 Series Cylinder Kits

Product	Model/ Specification	Part name	Material	Part name	Material
 <p>MA Kits Bore size: Φ16,20,25,32,40</p> <p>MA6432 Kits (ISO6432) Bore size: Φ8,10,12, 16,20,25, 32,40,50,63</p>		Front cover	Aluminum alloy	Piston seal	NBR
		Back cover	Aluminum alloy	Wear ring	PA66
		Piston	Aluminum alloy	Self lubricating bearing	PTFE+Brass
		Piston rod(Without)	S45C hard chrome carbon steel	Magnet(optional)	RbFeb
		Barrel(Without)	Stainless Steel	Cushion needle	Brass
		Front Cover seal	NBR	Hexagon screw	Carbon steel
		Cushion seal	NBR	Nut	Carbon steel
		Piston rod O-ring	NBR		
		Cover O-ring	NBR		

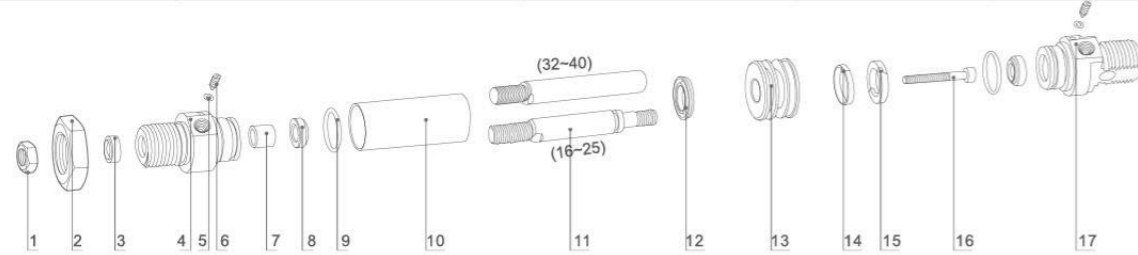

NO	Designation	NO	Designation	NO	Designation	NO	Designation	NO	Designation
1	Rod nut	5	O-ring	9	Cover O-ring	13	Piston	17	Back cover
2	Cover Nut	6	Adjustable screw	10	Barrel(Without)	14	Wear ring		
3	Front Cover seal	7	Self Lubricating bearing	11	Piston rod(Without)	15	Magnet(optional)		
4	Front cover	8	Cushion ring	12	Piston seal	16	Hexagon Screw		

MAL Series Cylinder Kits

Product	Model/ Specification	Part name	Material	Part name	Material
 <p>MAL Kits Bore size: Φ16,20, 25,32,40</p>		Front cover	Aluminum alloy	Piston seal	NBR
		Back cover	Aluminum alloy	Wear ring	PA66
		Piston	Aluminum alloy	Self lubricating bearing	PTFE+Brass
		Piston rod(Without)	S45C hard chrome carbon steel	Magnet(optional)	RbFeb
		Barrel(Without)	Hard anodized aluminum	Cushion needle	Brass
		Anti-bump cushion	NBR	Hexagon screw	Carbon steel
		Front Cover seal	NBR	Nut	Carbon steel
		Cushion seal	NBR	Profile bolt	Carbon steel
		Cover O-ring	NBR	Muffler	Cu

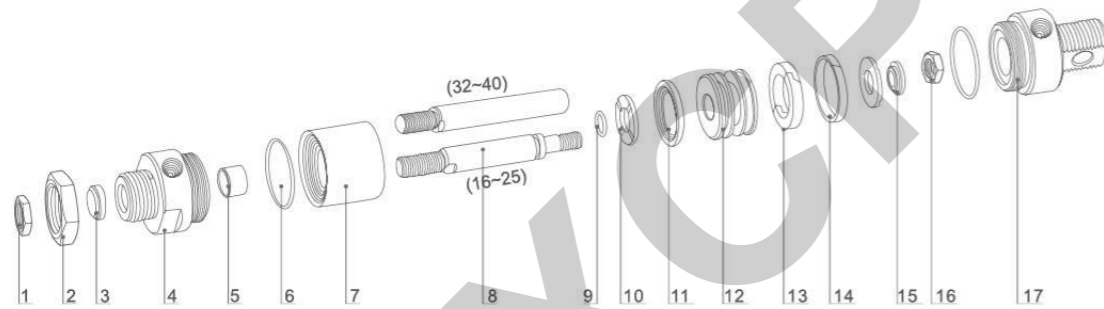

NO	Designation	NO	Designation	NO	Designation	NO	Designation	NO	Designation
1	Rod nut	5	Self Lubricating bearing	9	Rod O-ring	13	Magnet(optional)	17	Back cover
2	Cover Nut	6	Cover O-ring	10	Anti-bump cushion	14	Wear ring		
3	Front Cover seal	7	Barrel(Without)	11	Piston seal	15	Impact gasket		
4	Front cover	8	Piston rod(Without)	12	Piston	16	Nut		

Assembly Kits for Pneumatic Cylinder

SDA Series Cylinder Kits

Product	Model/ Specification	Part name	Material	Part name	Material
 <p>SDA Kits Bore size: Φ12,16,20, 25,32,40, 50,63,80,100</p>		Front cover	Aluminum alloy	Piston seal	NBR
		Back cover	Aluminum alloy	Self lubricating bearing	PTFE+Brass
		Piston	Aluminum alloy	Magnet(optional)	RbFeb
		Piston rod(Without)	S45C hard chrome carbon steel	C type buckle	Steel
		Barrel(Without)	Hard anodized aluminum	Nut	Carbon steel
		Anti-bump cushion	NBR	Muffler	Cu
		Cover O-ring	NBR		

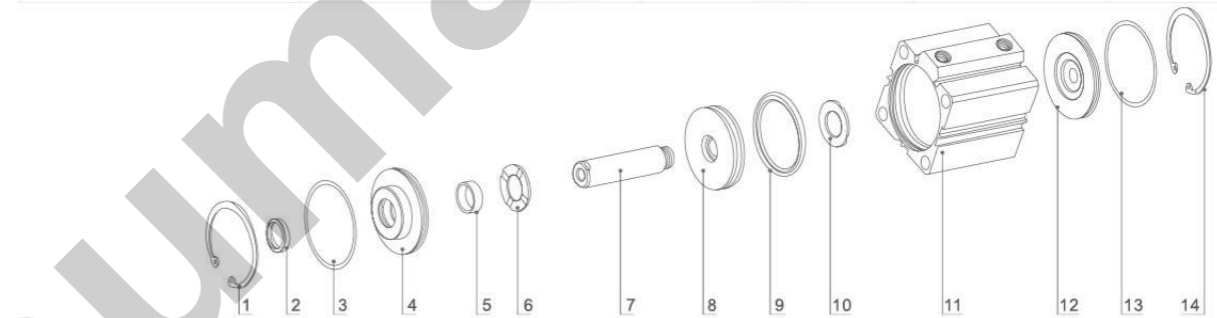

NO	Designation	NO	Designation	NO	Designation	NO	Designation	NO	Designation
1	C type buckle	4	Front cover	7	Piston rod(Without)	10	Anti-bump cushion	13	Cover O-ring
2	Front cover seal	5	Self Lubricating bearing	8	Piston	11	Barrel(Without)	14	C type buckle
3	Cover O-ring	6	Anti-bump cushion	9	Piston Seal	12	Back cover		

ADVU Series Cylinder Kits

Product	Model/ Specification	Part name	Material	Part name	Material
 <p>ADVU Kits (ISO6431) Bore size: Φ16,20, 25,32,40,50, 63,80</p>		Front cover	Aluminum alloy	Cover O-ring	NBR
		Back cover	Aluminum alloy	Piston seal	NBR
		Piston	Aluminum alloy	Wear ring	PA66
		Piston rod(Without)	S45C hard chrome carbon steel	Self lubricating bearing	PTFE+Brass
		Barrel(Without)	Hard anodized aluminum	Magnet(optional)	RbFeb
		Front Cover seal	NBR	Nut	Carbon steel
		Cushion seal	NBR	Profile bolt	Carbon steel
		Piston rod O-ring	NBR		

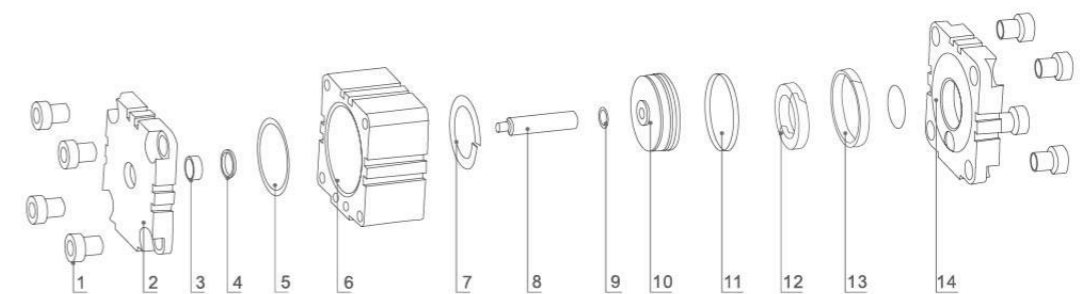

NO	Designation	NO	Designation	NO	Designation	NO	Designation
1	Profile bolt	5	Front Cover seal	9	Rod O-ring	13	Wear ring
2	Front cover	6	Barrel(Without)	10	Piston	14	Back cover
3	Self Lubricating bearing	7	Backup ring	11	Piston seal		
4	Cushion seal	8	Piston rod(Without)	12	Magnet(optional)		