

XMAC 2000~5000 Series Air Source Treatment Unit(F.R.L Combination)



XMAC4000-04

XMAC2000-02

Ordering Code

XMA	C	3000	04	<input type="checkbox"/>
Series XMA series	Function code Filter+Regulator+Lubricator	Specification Code 2000 3000 4000 5000	Port Size 01:G1/8" 02:G1/4" 03:G3/8" 04:G1/2" 06:G3/4" 10:G1"	Drain Type Blank:Manual Drain Type D:Auto Drain Type (Available for 3000 or above)

Graphic Symbol

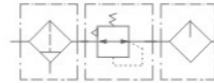

Specification

Model	XMAC2000-01	XMAC2000-02	XMAC3000-02	XMAC3000-03	XMAC4000-03	XMAC4000-04	XMAC4000-06	XMAC4000-06	XMAC5000-06	XMAC5000-10
Ensured Pressure Resistance	1.5MPa(15kgf/cm ²)									
Highest Working Pressure	1.0MPa(10kgf/cm ²)									
Operating Temperature Range	5~60°C									
Filter Precision	25 μ & 5 μ & 50 μ									
Recommended Oil Use	Turbine NO.1 Oil ISOVG32									
Container Material	Aluminum Die Casting									
Pressure Regulating Range	0.05~0.85MPa(0.05~0.85kgf/cm ²)									
Valve Type	With Overflow									
Assembly	Filter	XMAF2000	XMAF3000	XMAF4000	XMAF4000-06	XMAF5000				
	Regulator	XMAR2000	XMAR3000	XMAR4000	XMAR4000-06	XMAR5000				
	Lubricator	XMAL2000	XMAL3000	XMAL4000	XMAL4000-06	XMAL5000				
Rated Flow(L/min)	500	2000	4000	4500	5000					
Port Size(G)	1/8"	1/4"	1/4"	3/8"	3/8"	1/2"	3/4"	3/4"	1"	

Overall Dimensions

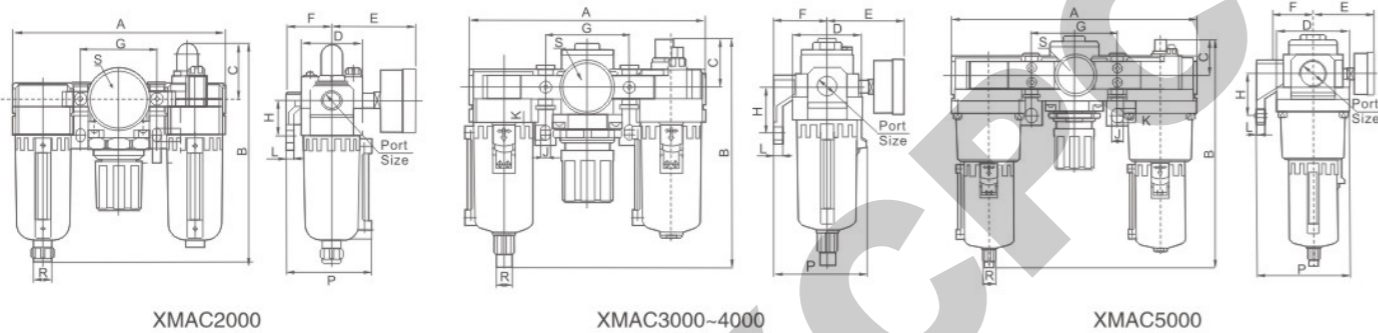

Dimension Sheet

Model	Port Size(G)	A	B	C	D	E	F	G	H	J	K	L	P	R	S
XMAC2000	G1/8"-G1/4"	140	147	38	40	56.8	30	50	24	5.5	8.5	5	56	φ6	G1/8
XMAC3000	G1/4"-G3/8"	181	178	38	53	60.8	41	64	35	7	11	7	70.5	φ8	G1/8
XMAC4000	G1/2"	238	207	41	70	65.5	50	84	40	9	13	7	87.5	φ8	G1/4
XMAC4000-06	G3/4"	253	208.5	40.5	70	69.5	50	89	40	9	13	7	87.5	φ8	G1/4
XMAC5000	G3/4"-G1"	300	287	48	90	75.5	69.8	105	50	12	16	10.5	115	φ8	G1/4

XMAC 2010~5010 Series Air Source Treatment Unit(FR.L Combination)



XMAC4010-04

XMAC2010-02

Ordering Code

XMA	C	3010	04	<input type="checkbox"/>
Series XMA series	Function code FR.L Combination	Specification Code 2010 3010 4010 5010	Port Size 01:G1/8" 02:G1/4" 03:G3/8" 04:G1/2" 06:G3/4" 10:G1"	Drain Type Blank:Manual Drain Type D:Auto Drain Type (Available for 3000 or above)

Graphic Symbol



Specification

Model	XMAC2010-01	XMAC2010-02	XMAC3010-02	XMAC3010-03	XMAC4010-03	XMAC4010-04	XMAC4010-06	XMAC4010-06	XMAC5010-06	XMAC5010-06
Ensured Pressure Resistance	1.5MPa(15kgf/cm ²)									
Highest Working Pressure	1.0MPa(10kgf/cm ²)									
Operating Temperature Range	5~60°C									
Filter Precision	25 μ & 5 μ & 50 μ									
Recommended Oil Use	Turbine NO.1 Oil ISOVG32									
Container Material	Aluminum Die Casting									
Pressure Regulating Range	0.05~0.85MPa(0.05~0.85kgf/cm ²)									
Valve Type	With Overflow									
Assembly	Filter with pressure reducer	XMAW2000	XMAW3000	XMAW4000	XMAW4000-06	XMAW5000				
	Lubricator	XMAR2000	XMAR3000	XMAR4000	XMAR4000-06	XMAR5000				
Rated Flow(L/min)	500	1700	3000	3000	4000					
Port Size(G)	1/8"	1/4"	1/4"	3/8"	3/8"	1/2"	3/4"	3/4"	1"	

Overall Dimensions

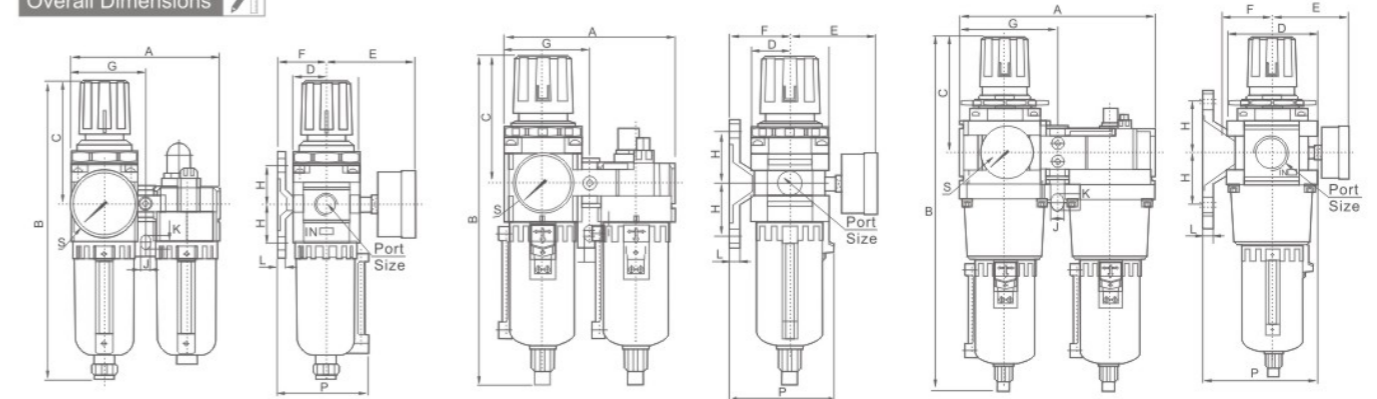

Dimension Sheet

Model	Port Size(G)	A	B	C	D	E	F	G	H	J	K	L	P	S
XMAC2010	G1/8"-G1/4"	90	186.5	78	40	56.8	30	45	24	5.5	8.5	5	56	G1/8
XMAC3010	G1/4"-G3/8"	117	232.5	92.5	53	60.8	41	58.5	35	7	11	7	69.5	G1/8
XMAC4010	G1/2"	154	277	112	70	65.5	50	77	40	9	13	7	87.5	G1/4
XMAC4010-06	G3/4"	164	282.5	114	70	69.5	50	82	40	9	13	7	87.5	G1/4
XMAC5010	G3/4"-G1"	195	353.5	116	90	75.5	69.8	97.5	50	12	16	10.5	115	G1/4