

2V Series 2/2 Solenoid Valve



Ordering Code

2V — **025** — **06** — **AC220V** — **V**

Specification Code
2V: Two-position Two-way Solenoid Valve

Aperture of Flow Rate
025: 2.5mm
130: 13mm
250: 25mm

Port Size
06: G1/8"
08: G1/4"
10: G3/8"
15: G1/2"
20: G3/4"
25: G1"

Standard Voltage
DC12V
DC24V
AC24V 50Hz/60Hz
AC110V 50Hz/60Hz
AC220V 50Hz/60Hz
AC380V 50Hz/60Hz

Oil Seal Code
Blank: NBR
V: VITON (For High temperature)

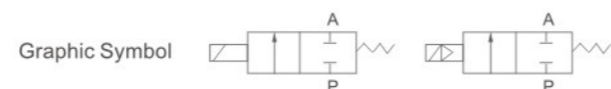

Specification

Model	2V025-06	2V025-08	2V130-10	2V130-15	2V250-20	2V250-25
Working Medium	Air, Water, Oil					
Motion Pattern	Direct Drive Type			Guide Type		
Type	Normal Close Type					
Aperture of Flow Rate (mm)	2.5		13		25	
CV Value	0.23		6.2		23	
Port Size	G1/8"	G1/4"	G3/8"	G1/2"	G3/4"	G1"
Operation Fluid Viscosity	20 CST (Below)					
Working-pressure	Air, Water, Oil 0~0.8MPa			Air, Water, Oil 0.05~0.7MPa		
Max. Pressure Resistance	12kgf/cm ²			10.5kgf/cm ²		
Operating Temperature Range	-10~+80°C					
Voltage Range	±10%					
Protect Class	IP65					
Power Consumption	AC: 7VA/860Hz PC: 6W					
Insulation	F Class					
Material of Body	Aluminum or Brass			Brass		
Material of Oil Seal	NBR or VITON					
Shortest Excitation Time	0.05 Second					

Internal structure

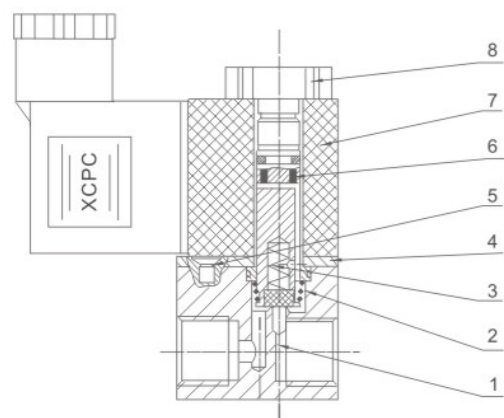

NO	Name
1	Body Of Valve
2	Spring
3	Assembly Of Iron Core
4	Assembly Of Iron Core
5	Cruciform Slot Screw
6	Platen
7	Coil
8	Nut

2V Series 2/2 Solenoid Valve

Internal structure

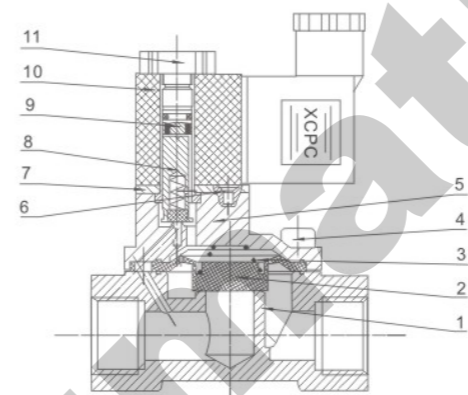

NO	Name
1	Body Of Valve
2	Diaphragm
3	Spring
4	Socket Hexagon Screws
5	Cover board
6	Cruciform Slot Screw
7	Platen
8	Assembly Of Iron Core
9	Assembly Of Iron Core
10	Coil
11	Nut

Overall Dimensions

