

XC Series Ball-Screw Type Electric Cylinder(Clean Room)



Ordering Code

XC50D — L10 — S800 — M2 — M — 100W — B

<b>Model</b>	<b>Lead</b>	<b>Stroke</b>	<b>Motor Direction</b>	<b>Motor Brand</b>	<b>Motor Output</b>	<b>Brake</b>
XC50D XC60D XC100D XC136D XC168D		100~1250mm	M1: Motor inside position (Available for 136) M2: Motor outside position M3: Motor outside, rightward position M4: Motor outside, leftward position M5: Motor outside, upper position M6: Motor outside, lower position	H: Hiwin S: Sanyo M: Mitsubishi Y: Yaskawa P: Panasonic F: Fuji D: Delta	100W~400W	

Specification

Model	XC50D	XC60D	XC100D				XC136D				XC168D									
AC Servo motor output (W)	100W												200W				400W			
Repeatability (mm)	±0.02																			
B.S (Φ)	12	12	12	12	16	16	16	16	16	16	16	16	25	20	20	25				
Lead (mm)	5	10	5	10	5	10	16	20	5	10	16	20	5	10	20	25				
Maximum speed (mm/sec)	250	500	250	500	250	500	800	1000	250	500	800	1000	250	500	800	1250				
Maximum payload (kg)	Level use (H)		9	5.5	30	15	50	35	25	20	80	70	65	35	110	80	75	65		
	Vertical use (V)		2.5	1.2	9	5	12	10	8	5	25	20	15	8	40	35	15	11		
Rated thrust (N)	70	35	250	130	300	150	85	75	640	320	225	160	945	480	240	200				
Stroke (mm)	100~800: 50(Interval)				100~1050: 50(Interval)				100~1250: 50(Interval)											

Motor Direction

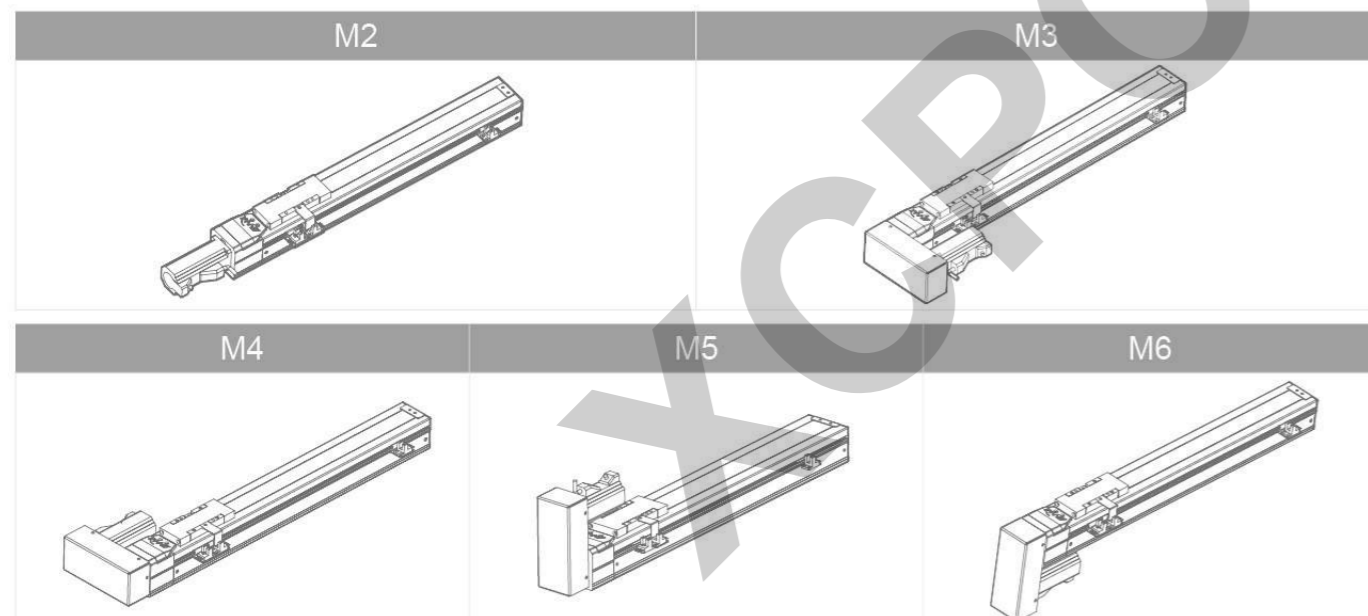

XB Series Belt Type Electric Cylinder(General)

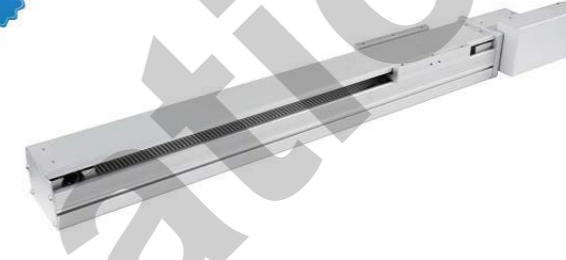

Ordering Code

XB50D — L35 — S500 — B1 — M — 100W — B

<b>Model</b>	<b>Equivalent to Lead</b>	<b>Stroke</b>	<b>Motor Direction</b>	<b>Motor Brand</b>	<b>Motor Output</b>	<b>Brake</b>
XB50D XB80D XB100S XB100D XB136D XB168D XB202D		100~3050mm	B1: Motor leftward, upper position B2: Motor rightward, upper position B3: Motor leftward, horizontal position B4: Motor rightward, horizontal position B5: Motor leftward, lower position B6: Motor rightward, lower position	H: Hiwin S: Sanyo M: Mitsubishi Y: Yaskawa P: Panasonic F: Fuji B: Beita	100~400W	

Specification

Model	XB50D	XB80D	XB100S	XB100D	XB136D	XB168D	XB202D		
AC Servo motor output (W)	100W	100W	200W	100W	200W	100W	200W	200W	400W
Repeatability (mm)	±0.04								
Equivalent to lead	35	28	35	28	40	76			
Maximum speed (mm/sec)	1718	1400	1600	1400	32	45			
Maximum payload (kg)	8	20	28	10	15	20	25	2000	
Stroke (mm)	100~800: 50(Interval)	100~1500: 50(Interval)	150~1850: 50(Interval)		150~3050: 100(Interval)				

Motor Direction

